

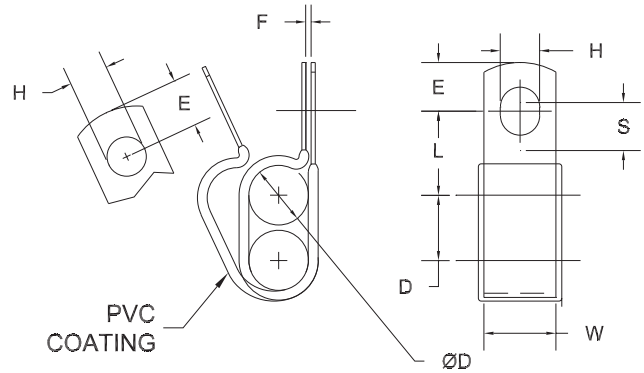

CLIP SPECIFICATIONS

Diameter: 3/16" - 1"
Bolt Size: #10 - 1/2"
Position: Furnished Open
Coating: Black Vinyl Plastisol Coating Per SAE J200
 0.032" Thick ± .015"
Notes: A clip that is designed to be slipped over two tubes or wires of the same diameter and closed with a bolt at assembly, one round hole and one slot for ease of alignment, and a developed shape for proper closing.

Material Code: A - SAE 1008/1010 G90 Per ASTM A653/653M
 Galvanized Steel
 B - SAE 1008/1010 Low Carbon Steel
 Zinc Plate per ASTM B633 Fe/Zn 8 Type II



PART NUMBER CALL OUT

F433-008 A Clamp Double Tube Coated, Galv, 1/2" Dia, 5/16" Bolt
 Material Code
 Base Part Number

Different sizes, materials, and/or finishes not shown can be manufactured to meet your specifications

Base Part Number	D	H	L	W	E	F	G	S
	Clamping Diameter	Hole Diameter	Center to Center	Width	Hole/Slot Center to End	Gap	Material Thickness	Slot Length
	± .015	± .005	± .031	± .010	± .015	± .032	± .002	± .020
F431-003	0.187	0.203	0.437	0.500	0.218	0.031	0.032	0.203
F432-003	0.187	0.281	0.468	0.500	0.312	0.031	0.032	0.375
F433-003	0.187	0.343	0.531	0.625	0.375	0.031	0.032	0.437
F434-003	0.187	0.406	0.593	0.750	0.437	0.031	0.032	0.500
F431-004	0.250	0.203	0.468	0.500	0.218	0.031	0.032	0.203
F432-004	0.250	0.281	0.500	0.500	0.312	0.031	0.032	0.375
F433-004	0.250	0.343	0.562	0.625	0.375	0.031	0.032	0.437
F434-004	0.250	0.406	0.625	0.750	0.437	0.031	0.032	0.500
F432-005	0.312	0.281	0.531	0.500	0.312	0.031	0.032	0.375
F433-005	0.312	0.343	0.593	0.625	0.375	0.031	0.032	0.437
F434-005	0.312	0.406	0.656	0.750	0.437	0.031	0.032	0.500
F432-006	0.375	0.281	0.562	0.500	0.312	0.062	0.032	0.375
F433-006	0.375	0.343	0.625	0.625	0.375	0.062	0.032	0.437
F434-006	0.375	0.406	0.687	0.750	0.437	0.062	0.032	0.500
F435-006	0.375	0.468	0.750	0.875	0.500	0.062	0.032	0.562
F436-006	0.375	0.531	0.812	1.000	0.562	0.062	0.032	0.625
F432-007	0.437	0.281	0.593	0.500	0.312	0.062	0.032	0.375
F433-007	0.437	0.343	0.656	0.625	0.375	0.062	0.032	0.437
F434-007	0.437	0.406	0.718	0.750	0.437	0.062	0.032	0.500
F435-007	0.437	0.468	0.781	0.875	0.500	0.062	0.032	0.562
F436-007	0.437	0.531	0.843	1.000	0.562	0.062	0.048	0.625
F432-008	0.500	0.281	0.625	0.500	0.312	0.062	0.048	0.375
F433-008	0.500	0.343	0.687	0.625	0.375	0.062	0.048	0.437
F434-008	0.500	0.406	0.750	0.750	0.437	0.062	0.048	0.500
F435-008	0.500	0.468	0.812	0.875	0.500	0.062	0.048	0.562
F436-008	0.500	0.531	0.875	1.000	0.562	0.062	0.048	0.625
F432-009	0.562	0.281	0.656	0.500	0.312	0.062	0.048	0.375
F433-009	0.562	0.343	0.718	0.625	0.375	0.062	0.048	0.437
F434-009	0.562	0.406	0.781	0.750	0.437	0.062	0.048	0.500
F435-009	0.562	0.468	0.843	0.875	0.500	0.062	0.048	0.562



CLIP SPECIFICATIONS

Diameter: 3/16" - 1"
Bolt Size: #10 - 1/2"
Position: Furnished Open
Coating: Black Vinyl Plastisol Coating Per SAE J200 0.032" Thick ± .015"
Notes: A clip that is designed to be slipped over two tubes or wires of the same diameter and closed with a bolt at assembly, one round hole and one slot for ease of alignment, and a developed shape for proper closing.

Material Code: A - SAE 1008/1010 G90 Per ASTM A653/653M Galvanized Steel
 B - SAE 1008/1010 Low Carbon Steel Zinc Plate per ASTM B633 Fe/Zn 8 Type II

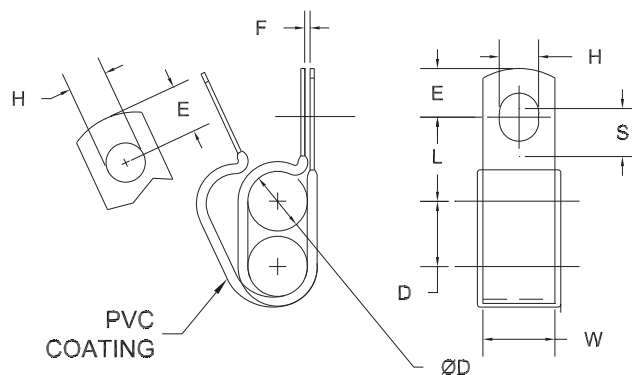

PART NUMBER CALL OUT

F433-008 A Clamp Double Tube Coated, Galv, 1/2" Dia, 5/16" Bolt
 Material Code
 Base Part Number

Different sizes, materials, and/or finishes not shown can be manufactured to meet your specifications

Base Part Number	D	H	L	W	E	F	G	S
	Clamping Diameter	Hole Diameter	Center to Center	Width	Hole/Slot Center to End	Gap	Material Thickness	Slot Length
	± .015	± .005	± .031	± .010	± .015	± .032	± .002	± .020
F436-009	0.562	0.531	0.906	1.000	0.562	0.062	0.048	0.625
F432-010	0.625	0.281	0.718	0.500	0.312	0.062	0.048	0.375
F433-010	0.625	0.343	0.750	0.625	0.375	0.062	0.048	0.437
F434-010	0.625	0.406	0.812	0.750	0.437	0.062	0.048	0.500
F435-010	0.625	0.468	0.875	0.875	0.500	0.062	0.048	0.562
F436-010	0.625	0.531	0.937	1.000	0.562	0.062	0.048	0.625
F433-011	0.687	0.343	0.781	0.625	0.375	0.062	0.048	0.437
F434-011	0.687	0.406	0.843	0.750	0.437	0.062	0.048	0.500
F435-011	0.687	0.468	0.906	0.875	0.500	0.062	0.048	0.562
F436-011	0.687	0.531	0.968	1.000	0.562	0.062	0.048	0.625
F433-012	0.750	0.343	0.812	0.625	0.375	0.062	0.048	0.437
F434-012	0.750	0.406	0.875	0.750	0.437	0.062	0.048	0.500
F435-012	0.750	0.468	0.937	0.875	0.500	0.062	0.048	0.562
F436-012	0.750	0.531	1.000	1.000	0.562	0.062	0.048	0.625
F433-013	0.812	0.343	0.843	0.625	0.375	0.062	0.060	0.437
F434-013	0.812	0.406	0.906	0.750	0.437	0.062	0.060	0.500
F435-013	0.812	0.468	0.968	0.875	0.500	0.062	0.060	0.562
F436-013	0.812	0.531	1.031	1.000	0.562	0.062	0.060	0.625
F433-014	0.875	0.343	0.875	0.625	0.375	0.062	0.060	0.437
F434-014	0.875	0.406	0.937	0.750	0.437	0.062	0.060	0.500
F435-014	0.875	0.468	1.000	0.875	0.500	0.062	0.060	0.562
F436-014	0.875	0.531	1.062	1.000	0.562	0.062	0.060	0.625
F433-015	0.937	0.343	0.906	0.625	0.375	0.062	0.060	0.437
F434-015	0.937	0.406	0.968	0.750	0.437	0.062	0.060	0.500
F435-015	0.937	0.468	1.031	0.875	0.500	0.062	0.060	0.562
F436-015	0.937	0.531	1.093	1.000	0.562	0.062	0.060	0.625
F433-016	1.000	0.343	0.937	0.625	0.375	0.062	0.060	0.437
F434-016	1.000	0.406	1.000	0.750	0.437	0.062	0.060	0.500
F435-016	1.000	0.468	1.062	0.875	0.500	0.062	0.060	0.562
F436-016	1.000	0.531	1.125	1.000	0.562	0.062	0.060	0.625

Warranty Disclaimer

The parts described herein are manufactured as set forth in the specifications listed for each part. Although we have taken reasonable efforts to include accurate and up to date information in this catalog, we make no warranty or representations as to its accuracy. We assume no liability or responsibility for any errors or omissions in the content of the catalog.

Every part listed in the catalog is provided to you "AS IS" WITHOUT WARRANTY OF ANY KIND, EITHER EXPRESS OR IMPLIED, INCLUDING, BUT NOT LIMITED TO, THE IMPLIED WARRANTIES OF MERCHANTABILITY, FITNESS FOR A PARTICULAR PURPOSE, OR NON-INFRINGEMENT.

THIS DISCLAIMER OF LIABILITY APPLIES TO ANY DAMAGES OR INJURY CAUSED BY ANY FAILURE OF PERFORMANCE, ERROR, OMISSION, INTERRUPTION, DELETION, DELAY IN OPERATION OR TRANSMISSION, COMMUNICATION LINE FAILURE, THEFT OR DESTRUCTION OR UNAUTHORIZED ACCESS TO, ALTERATION OF, OR USE OF RECORD, WHETHER FOR BREACH OF CONTRACT, TORTIOUS BEHAVIOR, NEGLIGENCE, OR UNDER ANY OTHER CAUSE OF ACTION. YOU ALSO SPECIFICALLY ACKNOWLEDGE AND AGREE THAT WE ARE NOT LIABLE FOR THE DEFAMATORY, OFFENSIVE OR ILLEGAL CONDUCT OF OTHER PERSONS AND THAT THE RISK OF INJURY FROM THE FOREGOING RESTS ENTIRELY WITH YOU.



**FRANKLIN
FASTENER**
Est. 1953

12701 Beech Daly Road
Redford, MI 48239-2456
U.S.A.

Phone: (313) 537-8900
Fax: (313) 537-0286
www.franklinfastener.com

© 2009 Franklin Fastener, Inc.
All Rights Reserved.
Produced in U.S.A.